

MC 3C - MC 4M

Instructions for use

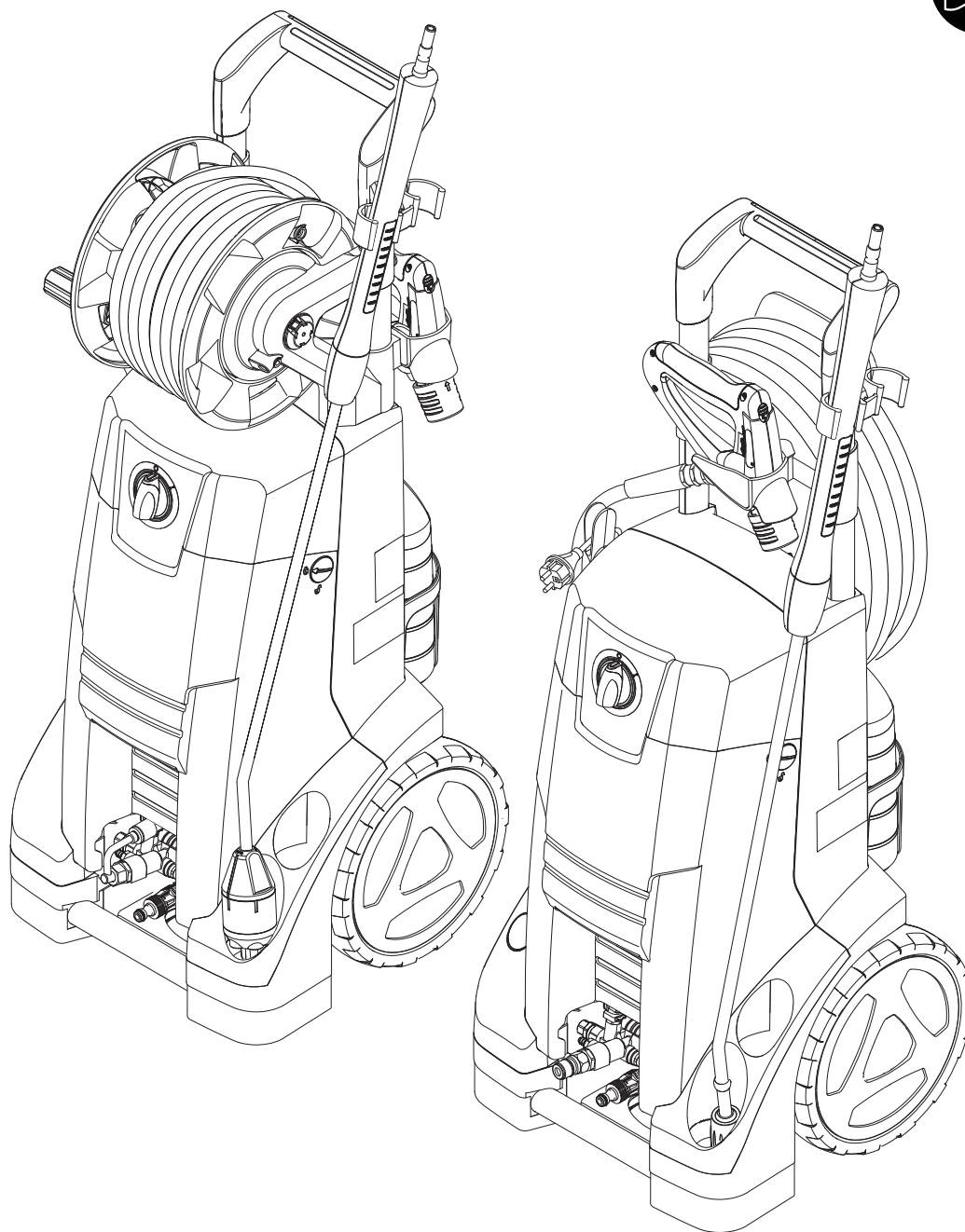

EN	Operating instructions	9
DE	Bedienungsanweisungen	11
FR	Instructions de fonctionnement	14
NL	Gebruiksaanwijzingen	17
IT	Istruzioni per l'uso	20
NO	Bruksanvisning	23
SV	Bruksanvisning	26
DA	Betjeningsvejledning	28
FI	Käyttöohje	30
ES	Instrucciones de funcionamiento	33
PT	Instruções de Funcionamento	36
EL	Οδηγίες λειτουργίας	39
TR	Kullanma Talimatları	42
SL	Navodila za delovanje	46
HR	Upute za uporabu	49
SK	Návod na obsluhu	52
CS	Návod k obsluze	55
PL	Instrukcje dotyczące obsługi	58
HU	Használati útmutató	61
RO	Instrucțiuni de utilizare	64
BG	Указания за експлоатация	67
RU	Руководство по эксплуатации	70
ET	Tööjuhised	73
LV	Norādījumi par ekspluatāciju	75
LT	Naudojimo instrukcija	78
JA	作手順.....	81
ZH	操作说明	84
KO	사용법.....	86
TH	คำแนะนำการใช้งาน.....	89
MS	Arahan Operasi.....	91

MC 3C-XT/MC 4M-XT

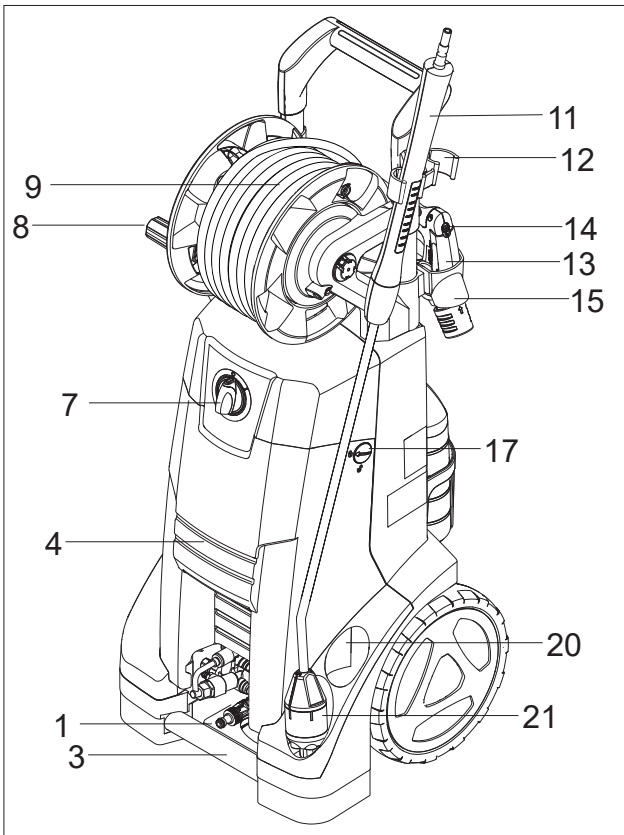

MC 3C/MC 4M

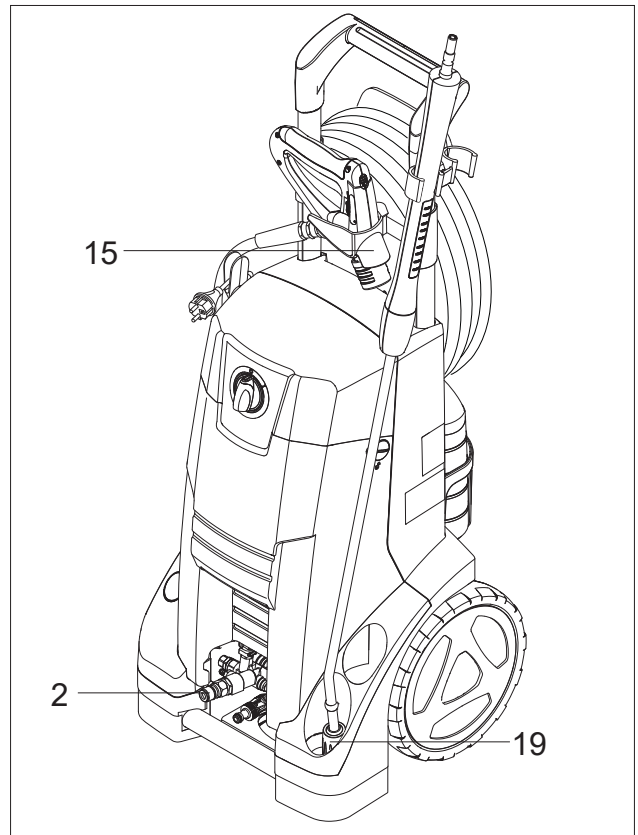

MC 3C-XT/MC 4M-XT

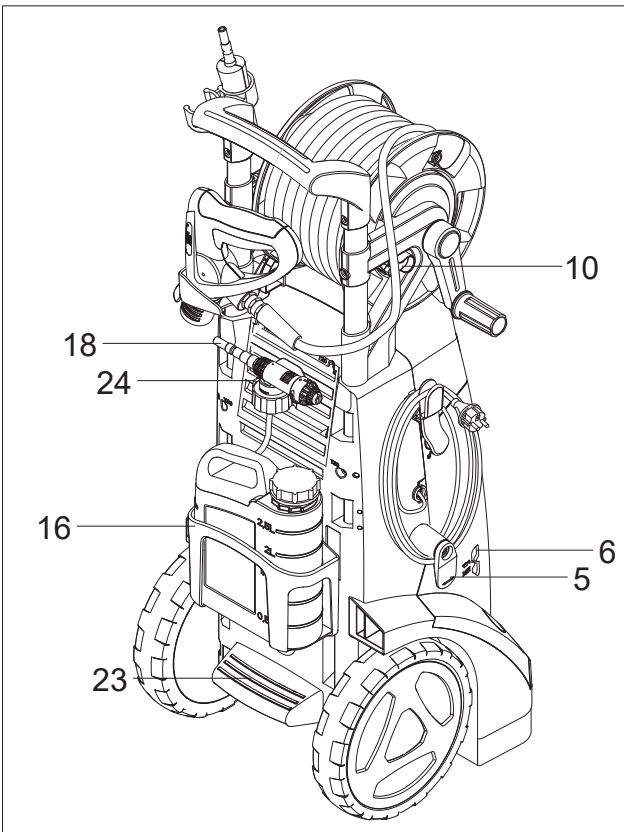

MC 3C/MC 4M

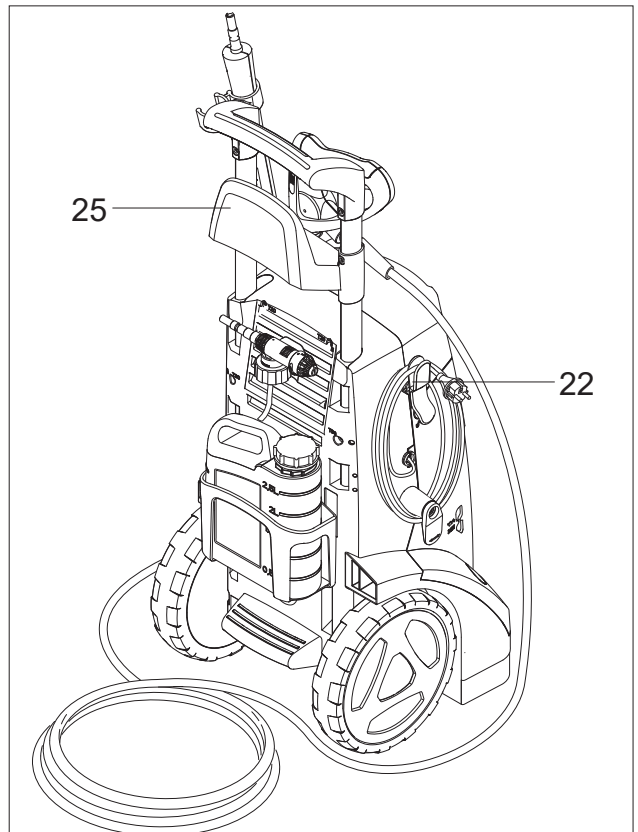

A - MC 3C-XT/MC 4M-XT

A - MC 3C/MC 4M

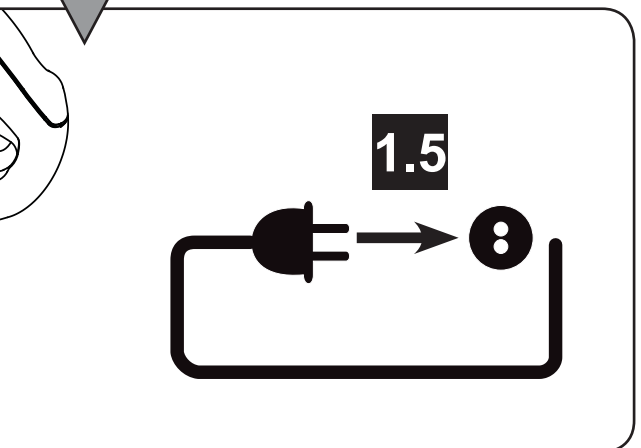
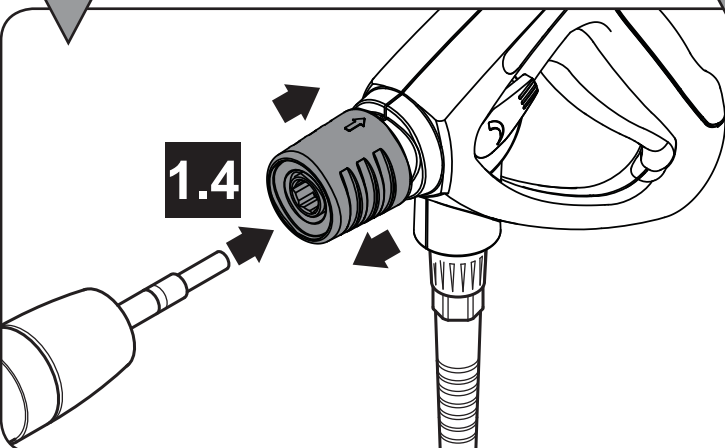
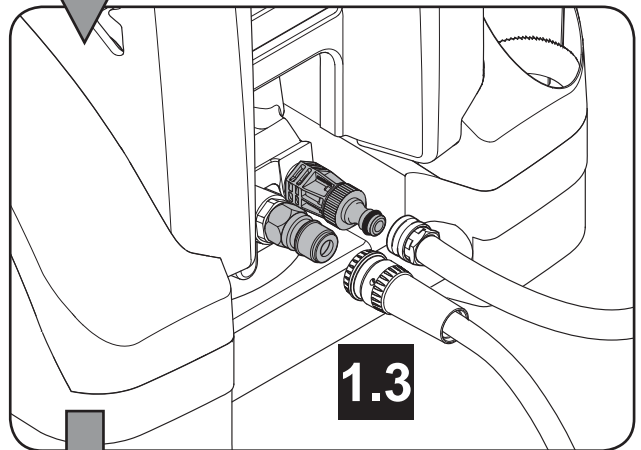
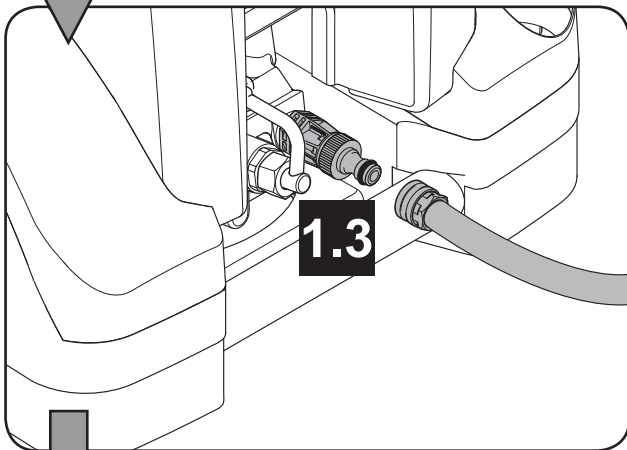
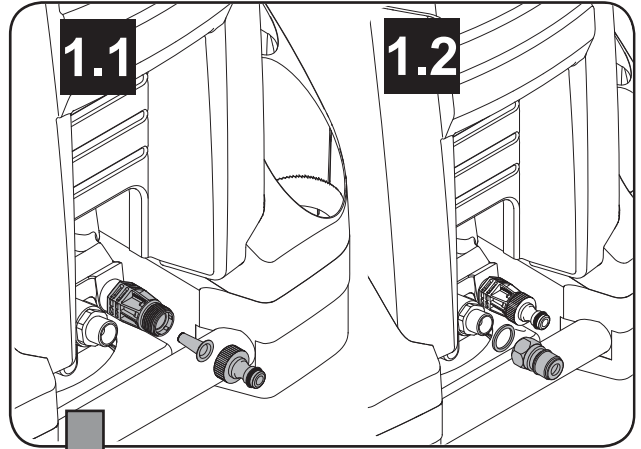
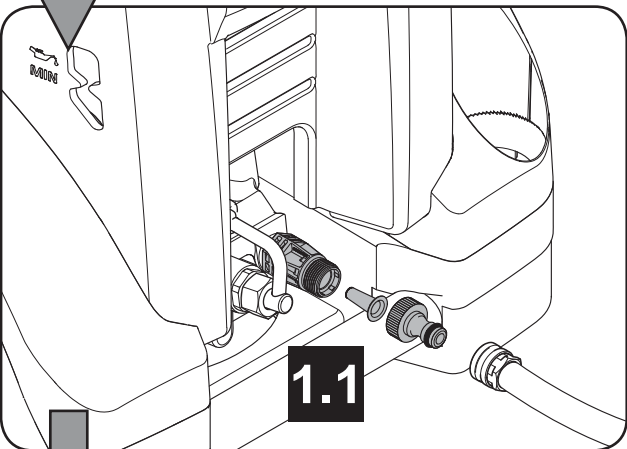
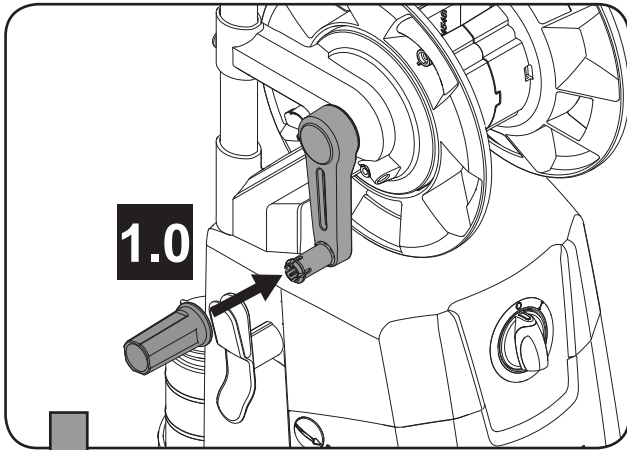

B - MC 3C-XT/MC 4M-XT

B - MC 3C/MC 4M

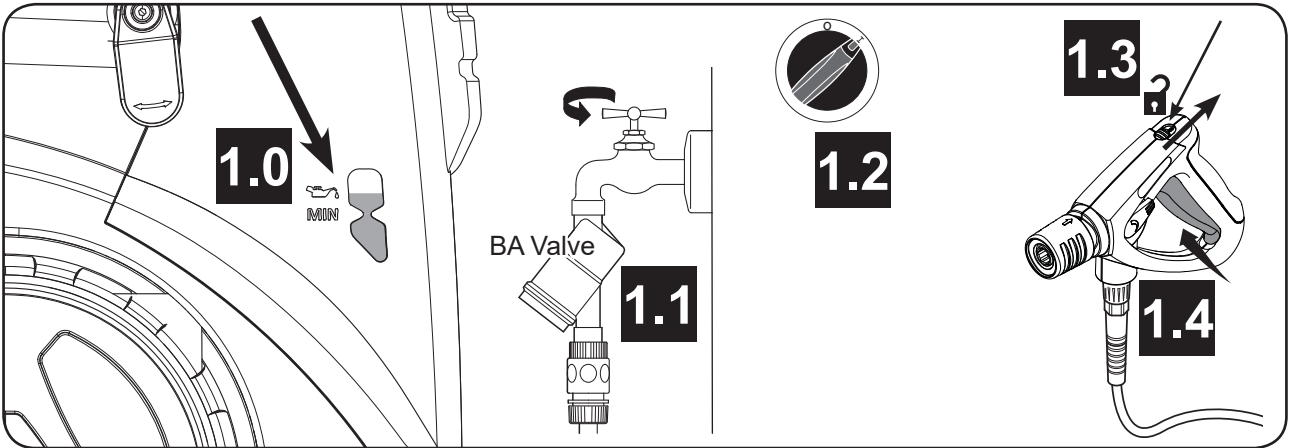

C - MC 3C-XT/MC 4M-XT

C - MC 3C/MC 4M

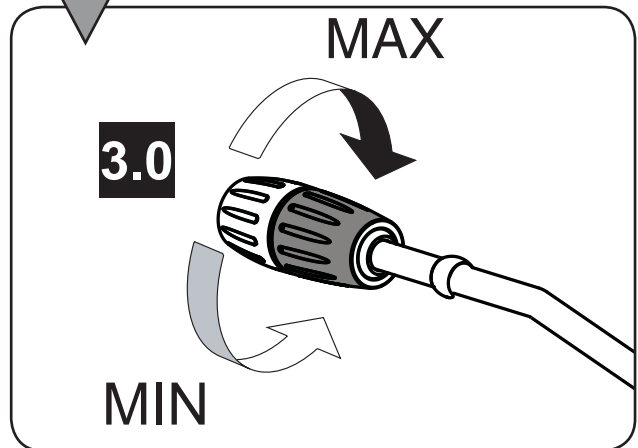
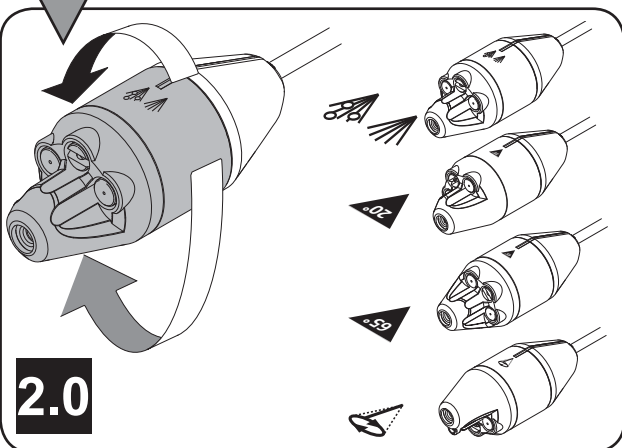
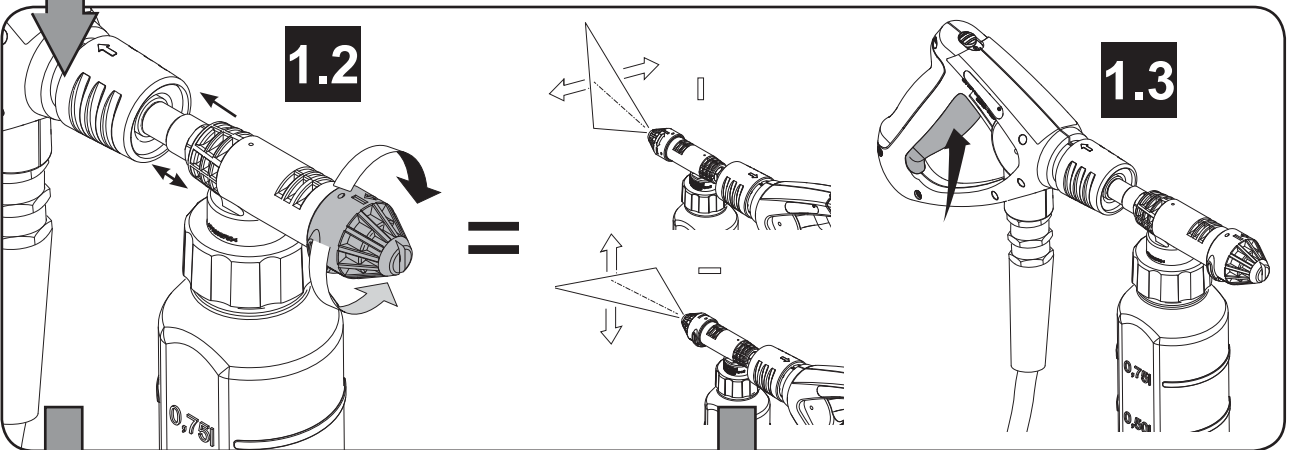
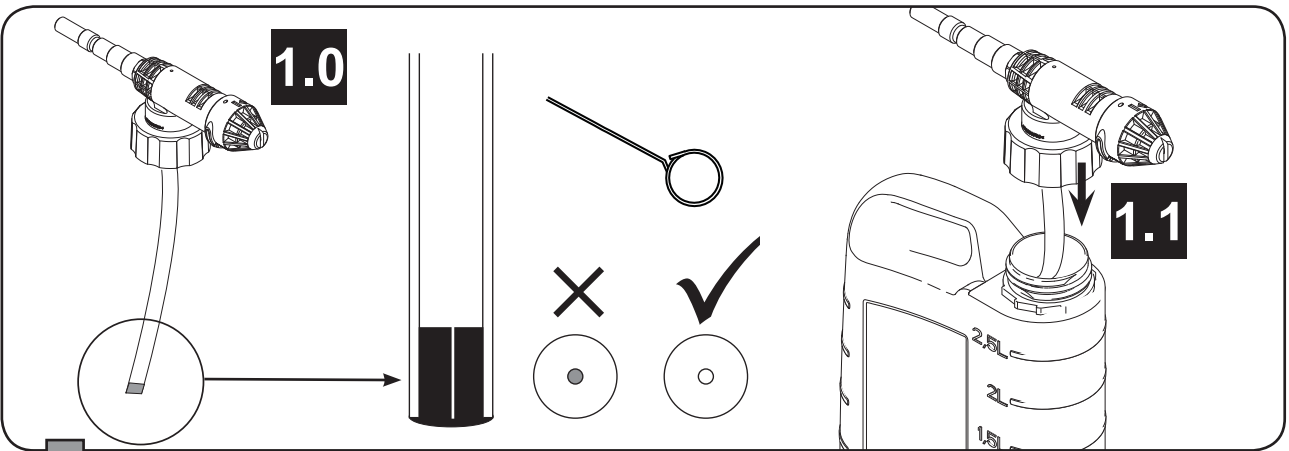

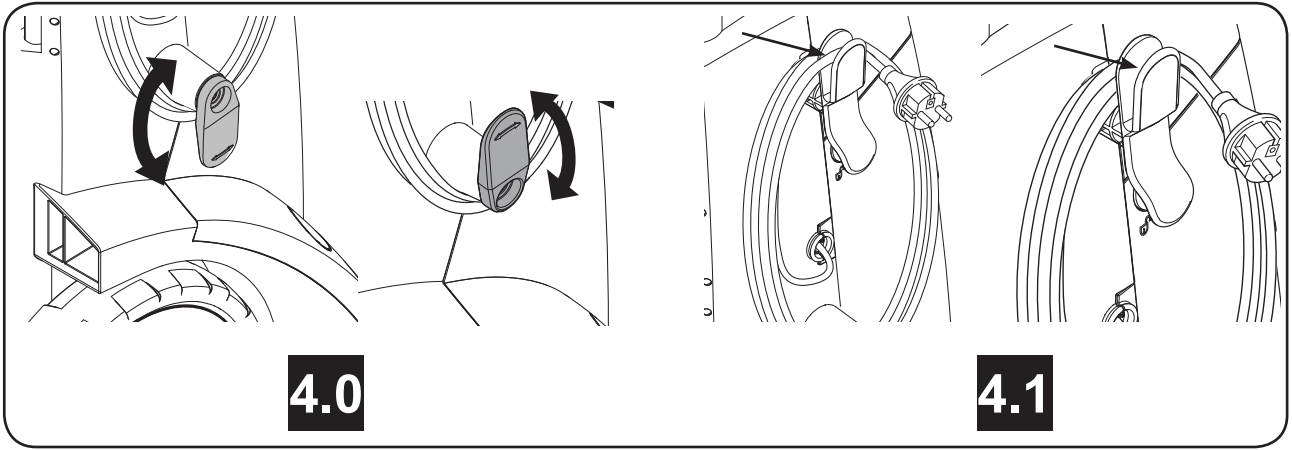

C - MC 3C-XT/MC 4M-XT

C - MC 3C/MC 4M

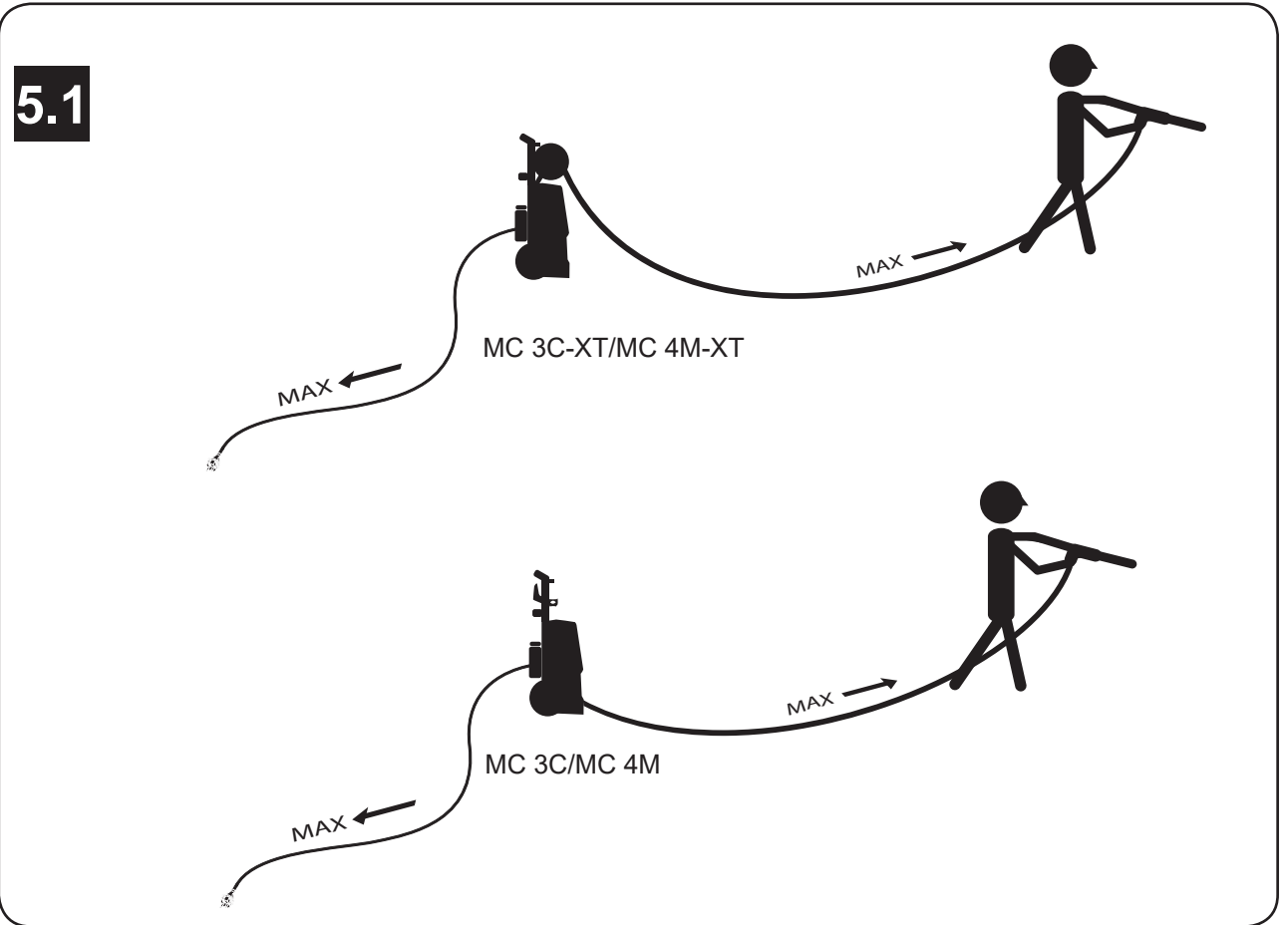
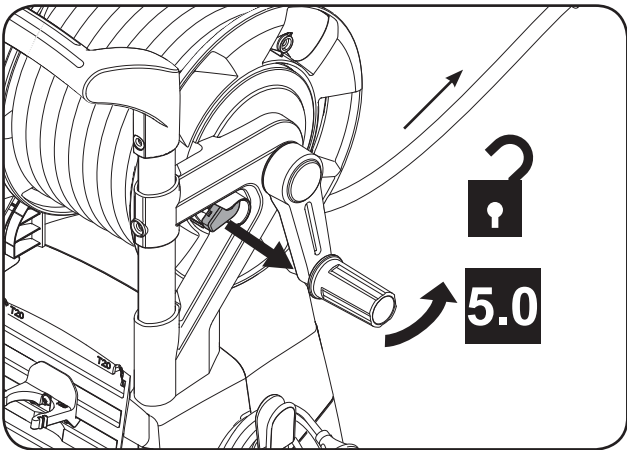

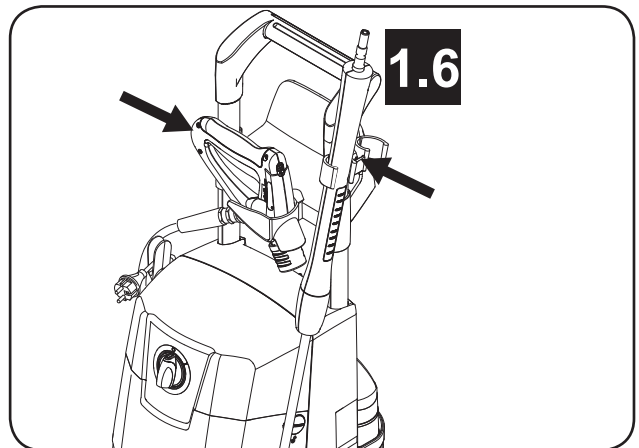
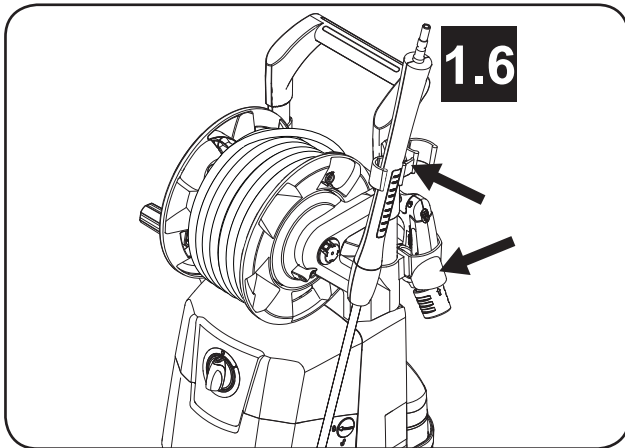
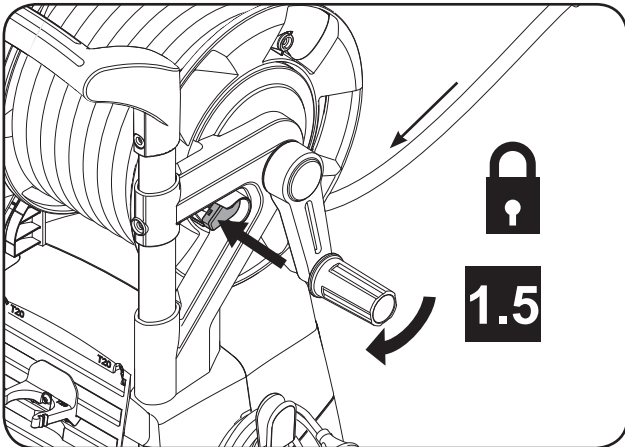
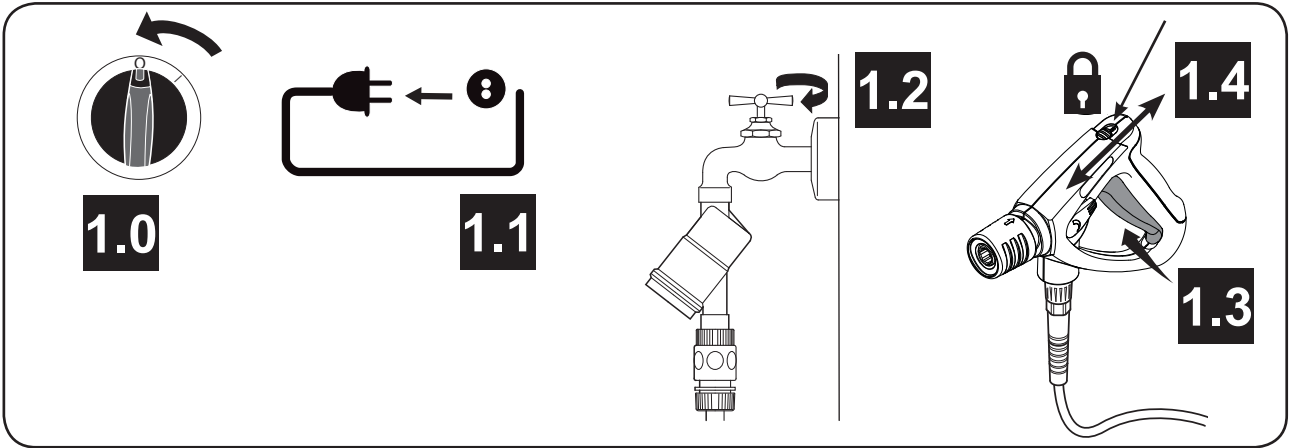

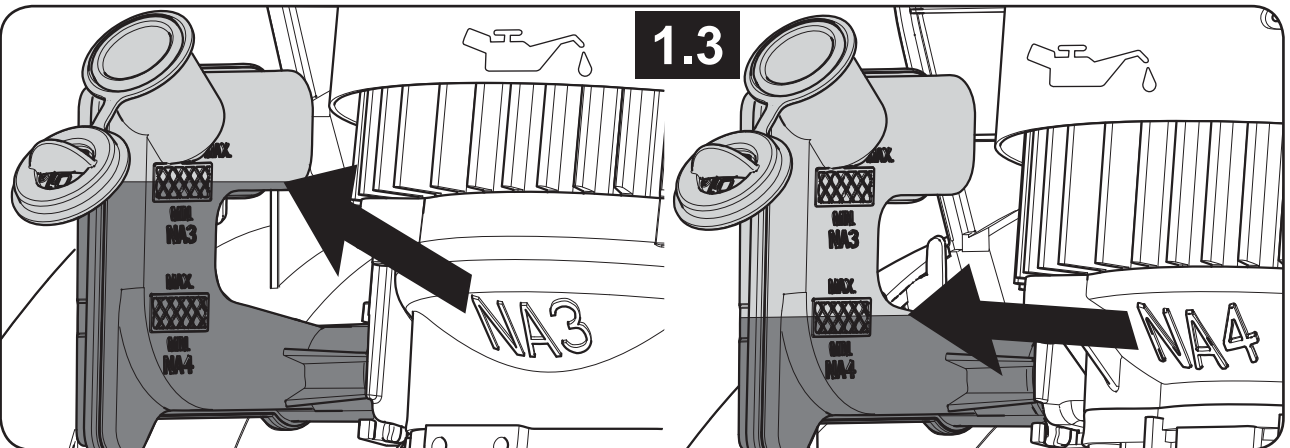
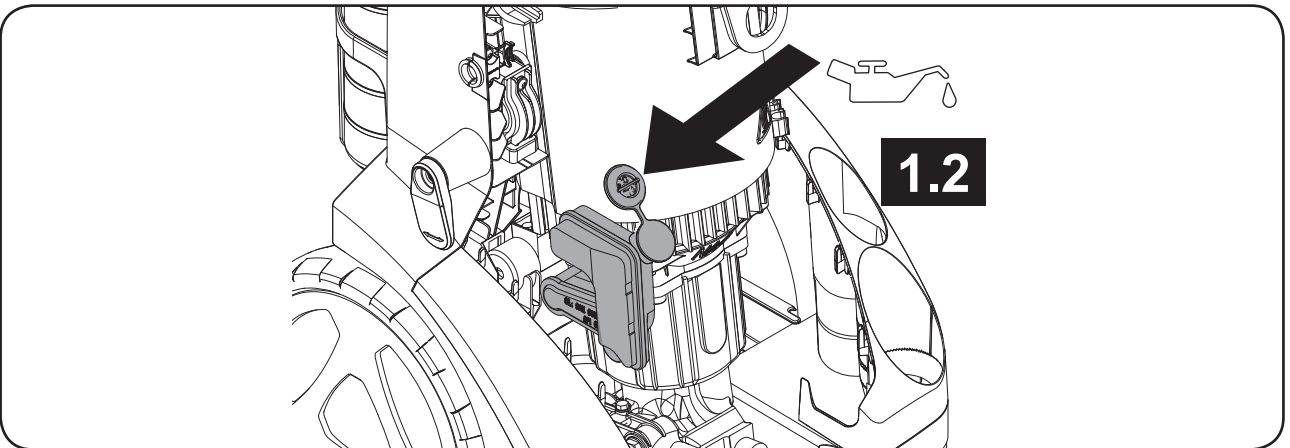
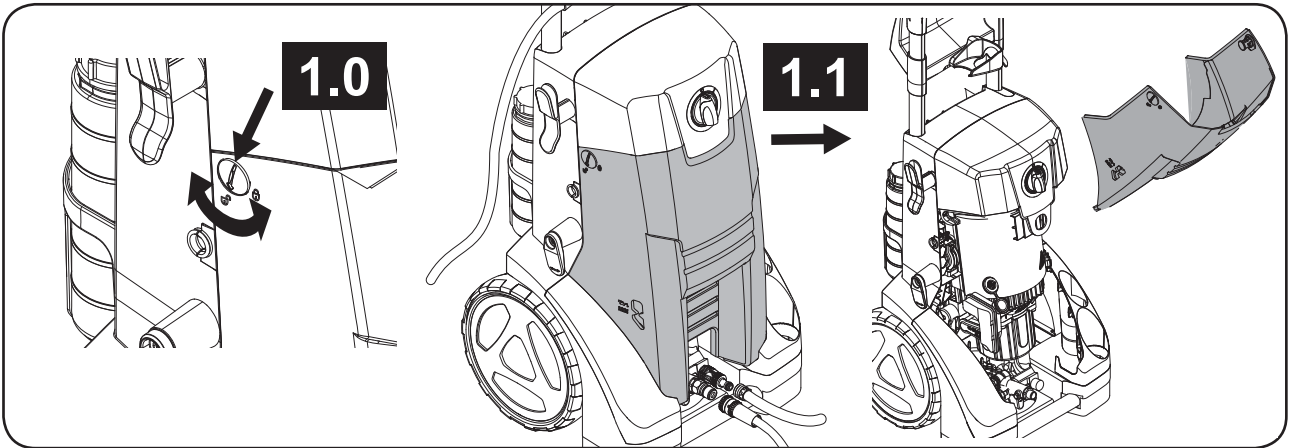

Hızlı başvuru kılavuzu

Bu yüksek basınçlı yıkama makinesi, tipik olarak aşağıdaki temizlik uygulamalarında profesyonel kullanım için tasarlanmıştır: yer/duvar, otomobil/kamyon, bina/inşaat, konteynır/varil ve esnafların kullanımı

Resimli hızlı başvuru kılavuzu

Resimli hızlı başvuru kılavuzu, birimi ilk çalıştırma da, kullanmada ve saklamada size yardımcı olmak için tasarlanmıştır. Kılavuz 5 bölüme ayrılmıştır.

A

Başlamadan önce

KULLANMADAN ÖNCE GÜVENLİK TALİMATLARINI OKUYUN!

Kullanım için gereken bileşenler:

1. Giriş su bağlantısı
2. Yüksek basınçlı hortum nipel
3. Kaldırma kolu
4. Kabin
5. Kablo açma parçası
6. Yağ gözetleme bölümü
7. Açma/kapama düğmesi
8. Hortum makarası tutamağı*)
9. Hortum makarası*)
10. Hortum makarası kilidi*)
11. Lans
12. Lans tutucusu
13. Ergo 2000 tabanca
14. Çocuk kilidi
15. Lans tutucusu*)
16. 2½ l'lik kaplı tutucu*)
17. Kabin kilidi
18. Köpük Püskürtücü *)
19. Flexo Power lans*)
20. Lans için yer
21. 4'-in-1 boru*)
22. Kablo ucu sabitlemesi
23. Ayak basma yeri
24. Köpük Püskürtücü/Kap kapağı*)
25. Hortum kancası *)

Birimin birleştirilmesi:

- 1.0 Kolu hortum makarasına takın
- 1.1 Filtre ve Gardena bağlantı parçasını takın
- 1.2 Yüksek basınçlı çıkış yerine contayı ve 3/8"lik nipel takın
- 1.3 Hortumları bağlayın (su ve yüksek basınçlı hortum)
- 1.4 Lansı takın
- 1.5 Elektrik kablolarını elektrik prizine takın.

B

Birimin açılması

- 1.0 Yağ seviyesini kontrol edin (bkz. E1.2)
- 1.1 Su musluğunu açın
OBS: ortam sıcaklığı 0°C'den fazla ve 40°C'den düşük olmalıdır. Makine sıcaklığı 0°C'den düşük olmamalıdır.

- 1.2 Yüksek Basınçlı Yıkama Makinesini çalıştırın
- 1.3 Tetikteki çocuk kilidini açın
- 1.4 Sprey kolunu etkinleştirin

C

Kontrol/çalıştırma

Temizlik maddelerinin kullanılması:

- 1.0 Köpük Püskürtücüde emme sınırlandırıcısını kontrol edin / temizleyin
- 1.1 Köpük Püskürtücüyü kaba takın
- 1.2 Yatay/dikey olarak püskürtme kolunu ayarlayın
- 1.3 Püskürtme kolunu etkinleştirin

4-in-1 Lansta nozul seçimi (XT modelleri):

- 2.0 Başlığı döndürün ve nozulu seçin

Flexo Power lansta basıncı ayarlayın (Standart modeller):

- 3.0 Ağız başlığının mavi kısmını Min./ max. işaretlerine döndürün

Kablo açma ve saklama:

- 4.0 Kabloyu açmak/saklamak için kablo kancasını döndürün
- 4.1 Kullandıktan sonra kablo ucunu Hortum kancasına sabitleyin

Hortum makarasını açma:

- 5.0 Hortum makarası kilidini açın ve hortumu çekip çıkartın
- 5.1 Kullanım sırasında hortumunun tam olarak açık olması GEREKMEKTEDİR

D

Birimi kullandıktan sonra

- 1.0 Yüksek Basınçlı Yıkama Makinesini Kapatın
- 1.1 Şebeke elektriğinden ayırın
- 1.2 Suyu kapatın
- 1.3 Hortum ve lans içerisindeki suyu boşaltın
- 1.4 Çocuk kilidini ayarlayın
- 1.5 Hortumu sarın ve hortum makarasını kilitleyin
- 1.6 Tetik ve lansı yerine yerleştirin

E

Bakım

- 1.0 Kabin kilitlelerini açarak kabini açın (madeni para ya da tornavida kullanın)
- 1.1 Kabini çıkartın
- 1.2 Yağı kontrol edin / max. seviyesine kadar doldurun (SAE 80W-90)
- 1.3 Max. yağ - pompa tipi MC 3C (NA3) ya da MC 4M (NA4)

Kullanma talimatları

Sorun Giderme MC 3C-MC 4M

Hata	Nedeni	Çözümü
Basınç dalgalanmaları	Emme hortumunda hava var.	Hortumu suyla doldurun ve tekrar bağlayın
	Yeterli su beslemesi yok	Durun! İlgili su beslemesi ya da hortum pompa Qmax. belirtene kadar
	Su filtresi tıkalı	Su filtresini durulayın
	Yüksek basınçlı ağız tıkanmış/aşınmış	Ağız temizleyin ya da aynı boyutlu bir ağızla değiştirin
	Emme yüksekliği aşıldı	Belirtildiği gibi en fazla emme yüksekliği elde edilene kadar bekleyin
Köpük Püskürtücü köpük oluş-turmuyor	Kullanılan deterjan köpürmeyen türde	Yalnızca köpürtücü madde içeren deterjanları kullanın.
	Emme hortumundaki ağız tıkalı ya da kurumuş sabunla dolu	Deterjan sınırlandırıcıyı temizleyin / ılık suyla yıkayın.
	Köpük Püskürtücüdeki köpük süngerini tıkalı.	1 Köpük püskürtücüyü yıkayın ve 8 saat ya da daha uzun bir süre ılık suda bekletin 2 Ya da Köpük püskürtücünün ön tarafını çıkartın SS köpük süngerini değiştirin ya da yıkayın
	Deterjan deposu boş	Deterjan deposunu doldurun
Birim açıldığında motor çalışmıyor ya da tekliyor	Elektrik kablosu bozuk	Elektrik kablosunun değiştirilmesi için uzman bir elektrikçiyle görüşün
	Fiş prize takılı değil	Fişi takın
	Ana sigorta atmış	Ana şalteri doğru konuma getirin
	Fiş ile kablo bağlantısı gevşek	Kablo üzerindeki fişi onarın/tekrar takın - uzman elektrikçi
	Pompa tıkalı ya da donmuş	Durun! Pompayı çözdürün ya da bayinin servis bölümüyle görüşün
	Termal koruyucu devreye girmiş	Durun! Makineyi en az 5 dakika boyunca soğutun

Bakım planı

	Haftalık	İlk 50 çalışma saatinden sonra	Her 200 çalışma saatinde	Gerektiği gibi
Su filtresinin temizlenmesi	A1.1			A1.1
Yağ seviyesinin kontrolü/doldurulması	B1.0/E1.2			
Pompa yağının değiştirilmesi		Bayi/servis bölümü ile görüşün	Bayi/servis bölümü ile görüşün	

Özel çalışma talimatları

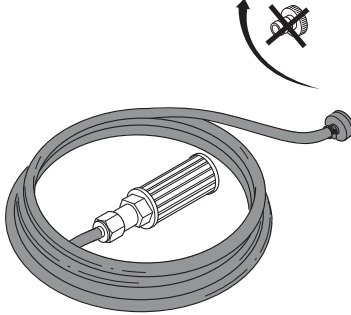
Kendiliğinden emiş		<p>0: HP hortumunu makineden çıkartın.</p> <p>1: Emme hortumu suyla doldurun ve Yüksek Basınçlı Yıkama Makinesini bağlayın (Öge no. 6400000)</p> <p>2: Emme hortumu bir hortum kelepçesi ile pompa girişine takın.</p> <p>3: Ana şalteri birkaç saniye boyunca "I" konumuna getirin. Pompadan su çıkana kadar ana şalteri birkaç kez açık ve kapalı duruma getirin.</p> <p>4: HP hortumunu, püskürtme kolunu ve boruyu takın.</p> <p>5: Ana şalteri "I" konumuna getirin.</p> <p>6: Püskürtme kolunu açın ve su havasız dışarı çıkana kadar birkaç kez çalıştırın.</p>
--------------------	---	--

Emme için gereken parçalar	Öge numarası
1 x Hortum Ağız 20R 3/4"	61369
1 x Hortum 3/4"	Maks. uzunluk 5 metre
1 x Hortum Kelepçesi 3/4"	
1 x Ayak valfli Emme Filtresi	6400000

Garanti

Cihazın kullanım ömrü 10 yıldır.

Cihazda izin verilmeyen değişikliklerin yapılması, yanlış yedek parçalar ve aksesuarlar kullanılmasından ve amacına uygun olmayan kullanımdan dolayı kaynaklanan zararlarda üretici sorumluluk üstlenmez.



Elektrikli ve Elektrikli Kullanılmış Cihazlara ilişkin 2012/19/EU sayılı Avrupa Direktifine göre kullanılmış elektrikli cihazların ayrı olarak biriktirilmesi ve çevreye uygun bir tekrar değerlendirme işlemine tabi tutulmaları gerekmektedir. Satın almış olduğunuz bu ürün, Atık Elektrikli Elektronik Eşyalar (AEEE) Yönetmeliği'ne uygundur.

Enerji Tasarrufu

Enerji tasarrufu için makineyi kullanmadığınız sürece kapalı konumda tutunuz.

ÜRETİCİ FİRMA :

Nilfisk A/S

Kornmarksvej 1

DK-2605 Broendby, Denmark

Tel.: +45 4328 8100

www.nilfisk.com

İTHALATÇI FİRMA :

Nilfisk A.S

Serifali Mh. Bayraktar Bulv. Sehit Sk. No:7

Ümraniye, 34775 İstanbul, Türkiye

Tel: +90 216 466 94 94

Faks: +90 216 527 30 32

www.nilfisk.com.tr

ÜRETİM YERİ :

MACARİSTAN

TÜKETİCİNİN SEÇİMLİK HAKLARI

Malın ayıplı olduğunun anlaşılması durumunda tüketici, 6502 sayılı

Tüketicinin Korunması Hakkında Kanununun 11 inci maddesinde yer alan;

a- Sözleşmeden dönme,

b- Satış bedelinden indirim isteme,

c- Ücretsiz onarılmasını isteme,

ç- Satılanın ayıpsız bir misli ile değiştirilmesini isteme,

haklarından birini kullanabilir.

Tüketicinin bu haklardan ücretsiz onarım hakkını seçmesi durumunda

satıcı, işçilik masrafı, değiştirilen parça bedeli ya da başka herhangi bir ad

altında hiçbir ücret talep etmeksizin malın onarımını yapmak veya

yaptırmakla yükümlüdür. Tüketici ücretsiz onarım hakkını üretici veya

ithalatçıya karşı da kullanabilir. Satıcı, üretici ve ithalatçı tüketicinin bu

hakkını kullanmasından müteselsilen sorumludur.

*Tüketicinin, **ücretsiz onarım hakkını** kullanması halinde malın;*

- Garanti süresi içinde tekrar arızalanması,

- Tamiri için gereken azami sürenin aşılması,

- Tamirinin mümkün olmadığının, yetkili servis istasyonu, satıcı, üretici

veya ithalatçı tarafından bir raporla belirlenmesi durumlarında;

tüketici malın bedel iadesini, ayıp oranında bedel indirimini veya imkân

varsa malın ayıpsız misli ile değiştirilmesini satıcıdan talep edebilir.

Satıcı, tüketicinin talebini reddedemez. Bu talebin yerine getirilmemesi

durumunda satıcı, üretici ve ithalatçı müteselsilen sorumludur.

*Satıcı tarafından **Garanti Belgesinin** verilmemesi durumunda, tüketici **Gümrük ve Ticaret Bakanlığı Tüketicinin Korunması ve Piyasa Gözetimi Genel Müdürlüğüne** başvurabilir.*

Tüketici, çıkabilecek uyuşmazlıklarda şikayet ve itirazları konusundaki başvuruları

*yerleşim yerinin bulunduğu veya tüketici işleminin yapıldığı yerdeki **Tüketici Hakem Heyetine***

***veya Tüketici Mahkemesine** başvurabilir.*

Specifications

			MC 3C- 150/570 XT 230/1/50/13	MC 3C- 140/570 230/1/50/13	MC 3C- 150/660 230/1/50/16	MC 3C- 130/660 220/1/60/15	MC 3C- 150/660 XT 230/1/50/16	MC 3C- 160/770 400/3/50
1			UK 英国	UK 英国	EU 欧盟	exp 其他	EU 欧盟	EU 欧盟
2		V/ph/Hz	230/1/50	230/1/50	230/1/50	220/1/60	230/1/50	400/3/50
3		A	13	13	16	15	16	16
4		kW кВт	3,0	3,0	3,5	3,5	3,5	4,0
5		bar (MPa) Бар (МПа) 巴 (兆帕)	150 (15)	140 (14)	150 (15)	130 (13)	150 (15)	160 (16)
6		l/h л/час 升/小时	520	520	600	600	600	700
7		bar (MPa) Бар (МПа) 巴 (兆帕)	200 (20)	200 (20)	200 (20)	190 (19)	200 (20)	200 (20)
8		l/h	570	570	660	660	660	770
9		°C (°F)	60, >40 max. 1 h. (140, >104 max. 1 h.)					
10		bar (MPa) Бар (МПа) 巴 (兆帕)	10 (1)					
11		m 米	0,5					
12		mm 毫米	382x382x1017					
13		kg кг	38	35,7	35,7	35,7	38	35,7
14	 (IEC 60335-2-69)	dB(A)+/-2 дБ(А)+/-2	78	78	78	78	78	81
15	 (IEC 60335-2-69)	dB(A)+/-2 дБ(А)+/-2	91	91	91	91	91	94
16a		m/s ² 米/秒 ²	<2,5	<2,5	<2,5	<2,5	<2,5	<2,5
16b		m/s ² 米/秒 ²	<5,5	-	-	-	<5,5	-
17		N	25,0	24,2	28,9	26,9	28,9	34,8
18		l 升	0,42					
19			SAE 80W-90					

Specifications

			MC 3C- 150/570 XT 230/1/50/13	MC 3C- 150/570 230/1/50/13	MC 3C- 170/820 400/3/50	MC 3C- 170/820 220-440/3/60	MC 3C- 170/820 XT 400/3/50	MC 3C- 170/820 XT 230-400/3/50
1			EU 欧盟	EU 欧盟	EU 欧盟	exp 其他	EU 欧盟	NO, BE 挪威、比 利时
2		V/ph/Hz	230/1/50	230/1/50	400/3/50	220/440/3/60	400/3/50	230/400/3/50
3		A	13	13	16	15	16	16
4		kW кВт	3,0	3,0	4,4	4,4	4,4	4,4
5		bar (MPa) Бар (МПа) 巴 (兆帕)	150 (15)	150 (15)	170 (17)	170 (17)	170 (17)	170 (17)
6		l/h л/час 升/小时	520	520	750	750	750	750
7		bar (MPa) Бар (МПа) 巴 (兆帕)	200 (20)	200 (20)	200 (20)	200 (20)	200 (20)	200 (20)"
8		l/h	570	570	820	820	820	820
9		°C (°F)	60, >40 max. 1 h. (140, >104 max. 1 h.)					
10		bar (MPa) Бар (МПа) 巴 (兆帕)	10 (1)					
11		m 米	0,5					
12		mm 毫米	382x382x1017					
13		kg кг	38	35,7	35,7	35,7	38	38
14	 (IEC 60335-2-69)	dB(A)+/-2 дБ(A)+/-2	78	78	81	81	81	81
15	 (IEC 60335-2-69)	dB(A)+/-2 дБ(A)+/-2	91	91	94	94	94	94
16a	 (ISO 5349 a _h) 	m/s ² 米/秒 ²	<2,5	<2,5	<2,5	<2,5	<2,5	<2,5
16b	 (ISO 5349 a _h) 	m/s ² 米/秒 ²	<5,5	-	-	-	<5,5	<5,5
17		N	25,0	25,0	38,4	38,4	38,4	38,4
18		l 升	0,42					
19			SAE 80W-90					

Specifications

			MC 4M-140/620 230/1/50/13	MC 4M-140/620 230/1/50/13	MC 4M-100/770 230/1/50/13	MC 4M-140/620 XT 230/1/50/13	MC 4M-160/620 230/1/50/16
1			EU 欧盟	UK 英国	UK 英国	UK 英国	EU 欧盟
2		V/ph/Hz	230/1/50	230/1/50	230/1/50	230/1/50	230/1/50
3		A	13	13	13	13	16
4		kW кВт	2,9	2,9	2,8	2,9	3,0
5		bar (MPa) Бар (МПа) 巴 (兆帕)	140 (14)	140 (14)	100 (10)	140 (14)	160 (16)
6		l/h л/час 升/小时	580	580	720	580	560
7		bar (MPa) Бар (МПа) 巴 (兆帕)	200 (20)	200 (20)	150 (15)	200 (20)	200 (20)
8		l/h	620	620	770	620	620
9		°C (°F)	60, >40 max. 1 h. (140, >104 max. 1 h.)				
10		bar (MPa) Бар (МПа) 巴 (兆帕)	10 (1)				
11		m 米	0,5				
12		mm 毫米	382x382x1017				
13		kg кг	38,5	38,5	38,5	40,8	38,5
14	 (IEC 60335-2-69)	dB(A)+/-2 дБ(А)+/-2	73	73	73	73	73
15	 (IEC 60335-2-69)	dB(A)+/-2 дБ(А)+/-2	86	86	86	86	86
16a	 (ISO 5349 a _h) 	m/s ² 米/秒 ²	<2,5	<2,5	<2,5	<2,5	<2,5
16b	 (ISO 5349 a _h) 	m/s ² 米/秒 ²	-	-	-	<5,5	-
17		N	27,0	27,0	28,3	27,0	27,8
18		l 升	0,39				
19			SAE 80W-90				





Specifications





			MC 4M-160/620 240/1/50/15	MC 4M-150/620 220/1/60/15	MC 4M-160/620 XT 230/1/50/16	MC 4M-180/740 400/3/50	MC 4M-180/740 220-440/3/60	MC 4M-160/720 200/3/50
1			AU	exp 其他	NO, BE 挪威、比 利时	EU 欧盟	exp 其他	JP 日本
2		V/ph/Hz	240/1/50	220/1/60	230/1/50	400/3/50	220/440/3/60	200/3/50
3		A	15	15	16	16	15	20
4		kW кВт	3,0	3,0	3,0	4,0	4,0	3,5
5		bar (MPa) Бар (МПа) 巴 (兆帕)	160 (16)	150 (15)	160 (16)	180 (18)	180 (18)	160 (16)
6		l/h л/час 升/小时	560	560	560	660	660	660
7		bar (MPa) Бар (МПа) 巴 (兆帕)	200 (20)	200 (20)	200 (20)	200 (20)	200 (20)	200 (20)
8		l/h	620	620	620	740	740	720
9		°C (°F)	60, >40 max. 1 h. (140, >104 max. 1 h.)					
10		bar (MPa) Бар (МПа) 巴 (兆帕)	10 (1)					
11		m 米	0,5					
12		mm 毫米	382x382x1017					
13		kg кг	38,5	38,5	40,8	40	40	38,5
14	 (IEC 60335-2-69)	dB(A)+/-2 дБ(A)+/-2	73	73	73	76	76	76
15	 (IEC 60335-2-69)	dB(A)+/-2 дБ(A)+/-2	86	86	86	89	89	89
16a	 (ISO 5349 a _h) 	m/s ² 米/秒 ²	<2,5	<2,5	<2,5	<2,5	<2,5	<2,5
16b	 (ISO 5349 a _h) 	m/s ² 米/秒 ²	-	-	<5,5	-	-	-
17		N	27,8	26,9	27,8	34,8	34,8	32,8
18		l 升	0,42	0,39				
19			SAE 80W-90					



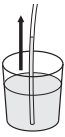

Specifications

			MC 4M- 160/720 200/3/60	"MC 4M- 180/740 XT 400/3/50	MC 4M- 180/740 XT 230-400/3/50	MC 4M- 150/620 XT 220/1/60/15
1			JP 日本	EU 欧盟	NO, BE 挪威、比利时	exp 其他
2		V/ph/Hz	200/3/60	400/3/50	230/400/3/50	220/1/60
3		A	20	16	16	15
4		kW кВт	3,5	4,0	4,0	3,0
5		bar (MPa) Бар (МПа) 巴 (兆帕)	160 (16)	180 (18)	180 (18)	150 (15)
6		l/h л/час 升/小时	660	660	660	560
7		bar (MPa) Бар (МПа) 巴 (兆帕)	200 (20)	200 (20)	200 (20)	200 (20)
8		l/h	720	740	740	620
9		°C (°F)	60, >40 max. 1 h. (140, >104 max. 1 h.)			
10		bar (MPa) Бар (МПа) 巴 (兆帕)	10 (1)			
11		m 米	0,5			
12		mm 毫米	382x382x1017			
13		kg кг	38,5	42,3	42,3	40,8
14	 (IEC 60335-2-69)	dB(A)+/-2 дБ(A)+/-2	76	76	76	73
15	 (IEC 60335-2-69)	dB(A)+/-2 дБ(A)+/-2	89	89	89	86
16a	 (ISO 5349 a _h) 	m/s ² 米/秒 ²	<2,5	<2,5	<2,5	<2,5
16b	 (ISO 5349 a _h) 	m/s ² 米/秒 ²	-	<5,5	<5,5	<5,5
17		N	32,8	34,8	34,8	26,9
18		l 升	0,39			
19			SAE 80W-90			

1			EN: Country variant. DE: Ländervarianten. FR: Selon le pays. NL: Nationale variant. IT: Variante per il Paese. NO: Variant i ulike land. SV: Landsvariant. DA: Landespecifik variant. FI: Maakohmainen vaihtelu. ES: Dependé del país. PT: Variante do país. EL: Έκδοση χώρας. TR: Ülke-deki model. SL: Jezikovna različica. HR: Ovisno o zemlji. SK: Vrsta ulja. CS: Varianta země. PL: Wersja dla kraju. HU: Országfüggő modellváltozatok. RO: Varianta țării. BG: Вариант за страната. RU: Региональное исполнение. ET: Riigi variant. LV: Valsts versija. LT: Šaliai skirtas variantas. JA: 国による相違。 ZH: 不同国家 KO: 국가별 모델. TH: แตกต่างกันไปตามประเทศ MS: Variasi negara.
2		V/ph/Hz	EN: Possible voltage. DE: Mögliche Spannung. FR: Tension autorisée. NL: Mogelijke spanning. IT: Possibile voltaggio. NO: Mulig spenning. SV: Möjlig spänning. DA: Spænding. FI: Mahdollinen jännite, V/vaiheluku/taajuus. ES: Tensión admitida. PT: Tensão possível. EL: Πιθανή τάση, V/ph/Frez. TR: Olası voltaj, V/Faz/Frekans. SL: Morebitna napetost. HR: Mogući napon. SK: Možné napätie. CS: Možné napětí. PL: Dopuszczalne napięcie, V/fazy/częst. HU: Tápészültség, V/fázis/frekv. RO: Tensiune posibilă, V/fază/Frecv. BG: Възможно напрежение. RU: Напряжение, В/φ./част. В/φ./Гц. ET: Võimalik pinge, V/faas/sagedus. LV: iespējamais spriegums. LT: Galima įtampa V / F / Frez. JA: 電圧。 ZH: 可能电压 (V / ph / Fréz) KO: 허용 전압, 볼트/상/헤르츠. TH: แรงดันไฟฟ้าที่สามารถใช้ได้ MS: Kemungkinan voltan.
3		A	EN: Fuse. DE: Sicherung. FR: Fusible. NL: Zekering. IT: Fusibile. NO: Sikring. SV: Säkring. DA: Sikring. FI: Sulake. ES: Fusible. PT: Fusível. EL: Ασφάλεια. TR: Sigorta. SL: Varovalka. HR: Osigurač. SK: Poistka. CS: Pojistka. PL: Bezpiecznik. HU: Biztosíték. RO: Siguranță. BG: Предпазител. RU: Предохранитель. ET: Kaitse. LV: Drošinātājs. LT: Saugiklis. JA: ヒューズ. ZH: 保险丝. KO: 퓨즈. TH: ฟิวส์. MS: Fius.
4		kW кВт	EN: Power rating. DE: Nennleistung. FR: Puissance nominale. NL: Nominiaal vermogen. IT: Corrente nominale. NO: Nominell effekt. SV: Märkeffekt. DA: Nominel effekt. FI: Tehontarve. ES: Potencia nominal. PT: Classificação de potência. EL: Ονομαστική ισχύς. TR: Elektrik değerleri. SL: Moč. HR: Oznaka napona. SK: Stanovenie výkonu. CS: Jmenovitý výkon. PL: Moc znamionowa. HU: Névleges teljesítmény. RO: Putere nominală. BG: Мощност. RU: Номинальная мощность кВт. ET: Vooluühik. LV: Nominālā jauda. LT: Galia. JA: 定格電力。 ZH: 额定功率. KO: 전원 등급. TH: อัตรากำลังไฟ. MS: Penarafan kuasa.
5		bar (MPa) Бар (МПа) 巴 (兆帕)	EN: Working pressure. DE: Arbeitsdruck. FR: Pression de service. NL: Werkdruk. IT: Pressione di esercizio. NO: Arbeidstrykk. SV: Arbetstryck. DA: Arbejdstryk. FI: Työpaine. ES: Presión de trabajo. PT: Pressão de trabalho. EL: Πίεση λειτουργίας. TR: Çalışma basıncı. SL: Delovni tlak. HR: Radni tlak. SK: Pracovný tlak. CS: Provozní tlak. PL: Ciśnienie robocze. HU: Üzemi nyomás. RO: Presiune de lucru. BG: Работно налягане. RU: Рабочее давление. ET: Töösurve. LV: Darba spiediens. LT: Darbinis slėgis. JA: 動作圧力。 ZH: 工作压力. KO: 작업 압력. TH: แรงดันขณะใช้งาน. MS: Tekanan kerja.
6		l/h л/час 升/小时	EN: Water flow. DE: Wasserdurchsatz. FR: Débit d'eau. NL: Waterdoorstroming. IT: Flusso dell'acqua. NO: Vanntilførsel. SV: Vattenflöde. DA: Vandmængde. FI: Vedenvirtaus. ES: Flujo de agua. PT: Fluxo de água. EL: Ροή νερού. TR: Su akışı. SL: Pretok vode. HR: Regulacija protoka vode. SK: Prietok vody. CS: Průtok vody. PL: Przepływ wody. HU: Vízfolyás. RO: Debit apă. BG: Воден поток. RU: Расход воды. ET: Veevool. LV: Ūdens plūsma. LT: Vandens srautas. JA: 流水. ZH: 水流量. KO: 급수량. TH: การไหลของน้ำ. MS: Aliran air.

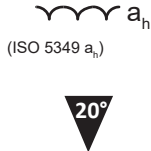
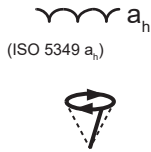
7		bar (MPa) Бар (МПа) 巴 (兆帕)	<p>EN: Max. water pressure. DE: Max Wasserdruck. FR: Pression d'eau maximale. NL: Max. waterdruk. IT: Max. pressione dell'acqua. NO: Maks. vanntrykk. SV: Max vattentryck. DA: Max. vandtryk. FI: Suurin vedenpaine. ES: Presión máxima de entrada del agua. PT: Pressão máxima de água. EL: Μέγ. πίεση νερού. TR: Maks. su basıncı. SL: Najv. vodni tlak. HR: Maksimalni tlak vode. SK: Maximálny tlak vody. CS: Max. tlak vody. PL: Maks. ciśnienie wody. HU: Max. víznyomás. RO: Presiune max. apă. BG: Макс. налягане на водата. RU: Макс. давление воды. ET: Max veesurve. LV: Maks. ūdens spiediens. LT: Maks. vandens slėgis. JA: 最高水圧 ZH: 最大水圧 KO: 최대 수압. TH: ความดันน้ำสูงสุด MS: Tekanan air maksimum.</p>
8		l/h	<p>EN: Water flow DE: Wasserdurchsatz. FR: Débit d'eau. NL: Waterdoorstroming. IT: Flusso dell'acqua. NO: Vanntilførsel. SV: Vattenflöde. DA: Vandmængde. FI: Vedevirtaus. ES: Flujo de agua. PT: Fluxo de água. EL: Ποή νερού. TR: Su akışı. SL: Pretok vode. HR: Protok vode. SK: Prietok vody. CS: Průtok vody. PL: Przepływ wody. HU: Vízátfolyás. RO: Debit apă. BG: Воден поток. RU: Расход воды. ET: Veevool. LV: Ūdens plūsma. LT: Vandens srautas. JA: 流水. ZH: 水流量 KO: 급수량. TH: การไหลของน้ำ MS: Aliran air.</p>
9		°C (°F)	<p>EN: Max water inlet temperature, Intake-Pressure operation. DE: Max Wassereinlasstemperatur - Druckbetrieb. FR: Température max. de l'entrée d'eau en mode admission/pression. NL: Max. Waterinlaattemperatuur Inlaat-Tijdens. Bedrijf. IT: Temperatura max. alimentazione acqua Funzionamento a ingressopressione. NO: Maks. temperatur vanninntak, Inntakstrykk drift. SV: Max ingående vattentemperatur inlopps-tryckdrift. DA: Maks. vandtilgangstemperatur, tilgangstrykdrift. FI: Tuloveden suurin lämpötila, käytettäessä painepesurina. ES: Temperatura y presión máxima de entrada del agua. PT: Temperatura máxima de entrada de água, Funcionamento da pressão de entrada. EL: Μεγ. θερμοκρασία εισόδου νερού-λειτουργίας πίεσης. TR: Maks. su girişi sıcaklığı Emme-Basınçlı çalışma. SL: Najv. vstopna temperatura vode, vstopni tlak pri delovanju. HR: Maks. temperatura ulazne vode, tlak pri usisavanju. SK: Max. vstupná teplota vody, Prevádzka v nasávacom režime pod tlakom. CS: Max. teplota vody na vstupu, provozní sací tlak. PL: Maks. temperatura na dopływie wody z instalacji wodociągowej. HU: Max. bemenő vízhőmérséklet Szívónyomásos üzem. RO: Temperatura max. de admisie apă în cazul alimentării de la robinet. BG: Макс. температура на входящата вода – работа в режим на засмукване. RU: Макс. температура воды на входе (всасывание/подача под давлением). ET: Max vee sisselasketemperatuur Sissevoturõhk töö ajal. LV: Maks. ūdens ieplūdes temperatūra ieplūdes-spiediena darbībā. LT: Didžiausia vandens paėmimo temperatūra, veikimas esant įėjimo slėgiui. JA: 最高流入水温度、吸気圧力動作. ZH: 进水压力操作时的最高进水水温 KO: 최대 급수 온도 주입/압력 작동. TH: อุณหภูมิน้ำเข้าสูงสุด ความดันในการใช้งานบริเวณทางเข้า MS: Suhu maksimum air masuk, Kemasukan-Operasi tekanan.</p>
10		bar (MPa) Бар (МПа) 巴 (兆帕)	<p>EN: Max. water inlet pressure. DE: Max. Wassereinlassdruck. FR: d'eau en mode admission/pression. NL: Max. waterinlaatdruk. IT: Pressione max. alimentazione acqua. NO: Maks. trykk vanninntak. SV: Max tryck för vatteninlopp. DA: Maks. Vandtilgangstryk. FI: Tuloveden suurin paine. ES: Presión máxima de entrada del agua. PT: Pressão máxima de entrada de água. EL: Μέγ. πίεση εισόδου νερού. TR: Maks. su girişi basıncı. SL: Najv. tlak dovoda vode. HR: Maks. tlak ulazne vode. SK: Max. vstupný tlak vody. CS: Max. tlak vody na vstupu. PL: Maks. ciśnienie na dopływie wody. HU: Max. bemenő nyomás. RO: Presiunea max. de alimentare cu apă. BG: Макс. налягане на входяща вода. RU: Макс. давление воды на входе. ET: Maks vee sissevoolusurve. LV: Maks. ūdens spiediens. LT: Didžiausias vandens paėmimo slėgis. JA: 最高流入水圧. ZH: 最大进水压力 KO: 최고 급수 압력. TH: ความดันน้ำเข้าสูงสุด MS: Tekanan maksimum air masuk.</p>

11		m 米	<p>EN: Max dry suction height. DE: Max. Trockensaughöhe. FR: Hauteur d'aspiration à sec max. NL: Max. droge aanzuighoogte. IT: Altezza massima di aspirazione secco. NO: Maks. sugehøyde tørr. SV: Max torr-sugningshöjd. DA: Maks. sugehøjde, tør. FI: Suurin kuivaimukorkeus. ES: Altura máxima de succión en seco. PT: Altura de aspiração a seco máx. EL: Μέγ. ύψος αναρρόφησης. TR: Maks. Kuru emme yüksekliği. SL: Najv. višina suhega vsesavanja. HR: Maks. visina pri suhom usisavanju. SK: Max. suchá nasávacia výška. CS: Max. sací výška nasucho. PL: Maks. wysokość ssania na sucho. HU: Max. száraz szívómagasság. RO: Înălțime max. de aspirare în cazul alimentării cu apă dintr-un recipient. BG: Макс. височина на сухо засмукване. RU: Макс. высота всасывания. ET: Max kuivimu kõrgus. LV: Maks. sausās sūkšanas augstums. LT: Maksimalus sausas įsiurbimo aukštis. JA: 最大乾燥吸込高さ。 ZH: 最大干吸高度 米 KO: 최대 건조 흡입 높이. TH: ความสูงของท่อดูดแห้งสูงสุด MS: Ketinggian maksimum sedutan kering.</p>
12		mm 毫米	<p>EN: Dimensions LxWxH. DE: Masse LxBxH. FR: Dimensions l x p x h. NL: Afmetingen LxBxH. IT: Dimensioni, lun. x larg. x alt. NO: Mål LxBxH. SV: Dimensioner LxBxH. DA: Mål LxBxH. FI: Mitat, PxLxK. ES: Dimensiones l x a x al. PT: Dimensões, C x L x A. EL: Διαστάσεις, Μ x Π x Υ. TR: Boyutlar, u x g x y. SL: Mere D x Š x V. HR: Dimenzije DxŠxV. SK: Rozmery D x Š x V. CS: Rozměry d x š x v. PL: Wymiary długość x szer. x wys. HU: Méretek H x Sz x M. RO: Dimensiuni. L x l x î. BG: Размери Д x Ш x В. RU: Размеры, Дл. x Шир. x Выс. ET: Mõõtmed p x l x k. LV: Izmēri G x P x A. LT: Matmenys (i x p x a). JA: 外形寸法長さx幅x高さ。 ZH: 尺寸 (长x宽x高) 毫米 KO: 크기(l x w x h). TH: ขนาด ยาว x กว้าง x สูง MS: Dimensi LxWxH.</p>
13		kg кг	<p>EN: Weight. DE: Gewicht. FR: Poids du nettoyeur. NL: Gewicht van de hogedrukreiniger. IT: Peso dell'idropulitrice. NO: Vekt høytrykksvasker. SV: Maskinens vikt. DA: Vægt. FI: Pelkän painepesurin paino. ES: Peso del limpiador. PT: Peso da máquina de limpeza. EL: Βάρος μηχανήματος καθαρισμού. TR: Temizlik makinesinin yüksekliği. SL: Masa. HR: Težina. SK: Hmotnosť. CS: Hmotnost čisticího stroje. PL: Ciężar myjki. HU: Tisztítógép tömege. RO: Greutatea aparatului. BG: Тегло. RU: Вес моечной машины. ET: Pesuri kaal. LV: Tīrītāja svars. LT: Valymo įrenginio svoris. JA: 重量。 ZH: 清洗机重量 KO: 세척기 무게. TH: น้ำหนัก MS: Berat.</p>
14	 (IEC 60335-2-69)	dB(A) +/-2 дБ(A) +/-2	<p>EN: Sound pressure level L_{PA}. DE: Schalldruckpegel FR: Niveau de pression acoustique NL: Geluidsdrukniveau IT: Livello pressione sonora NO: Lydtrykknivå SV: Ljudtrycksnivå DA: Lydtryksniveau FI: Äänenpainetaso ES: Nivel de presión sonora PT: Nível de pressão acústica EL: Επίπεδο πίεσης ήχου TR: Göre ses basıncı seviyesi SL: Raven zvočnega tlaka. HR: Razina zvučnog tlaka. SK: Hladina zvukového. CS: Hladina akustického tlaku PL: Poziom ciśnienia akustycznego HU: Hangnyomásszint RO: Nivel de presiune acustică BG: Ниво на звуково налягане RU: Уровень шума ET: Helisurve tase LV: Akustiskā spiediena līmenis LT: Garso slėgio lygis JA: 音圧レベル ZH: 声压级 KO: 음압 레벨 TH: ระดับความดันเสียง MS: Tahap tekanan bunyi</p>
15	 (IEC 60335-2-69)	dB(A) +/-2 дБ(A) +/-2	<p>EN: Sound power level L_{WA}. DE: Schallleistungspegel FR: Niveau de puissance acoustique NL: Geluidsvermogeniveau IT: Livello potenza sonora NO: Lydeffektnivå SV: Ljudeffektnivå DA: Lydeffektniveau FI: Äänen tehotaso ES: Potencia acústica PT: Nível de potência acústica EL: Επίπεδο ισχύος ήχου TR: Göre ses basıncı seviyesi SL: Raven moči zvoka. HR: Razina jakosti. SK: Hladina zvukového výkonu. CS: Hladina akustického výkonu PL: Poziom mocy akustycznej HU: Hangteljesítmény szint RO: Nivelul de putere acustică BG: Ниво на звукова мощност RU: Уровень звуковой мощности ET: Helivõimsuse tase LV: Akustiskās jaudas līmenis LT: Garso galios lygis JA: 音響パワーレベル ZH: 声功率级 KO: 소음 레벨 TH: ระดับกำลังเสียง MS: Tahap kuasa bunyi</p>

16a		m/s^2 米/秒 ²	EN: Vibration. DE: Vibrationen FR: Vibration NL: Vibratie IT: Vibrazioni NO: Vibrasjoner SV: Vibration DA: Vibration FI: Tärinäarvot ES: Vibración PT: Vibração EL: Δόνηση TR: Titreşimi SL: Vibracije. HR: Vibracije. SK: Vibrácie. CS: Vibrace PL: Drgania HU: Vibráció RO: Vibrații BG: Вибрации. RU: Вибрация ET: vibratsioon LV: vibrācija LT: Vibracijos JA: 振動。 ZH: 振动 KO: 진동 TH: แรงสั่นสะเทือน MS: Getaran.
16b		m/s^2 米/秒 ²	EN: Vibration. DE: Vibrationen FR: Vibration NL: Vibratie IT: Vibrazioni NO: Vibrasjoner SV: Vibration DA: Vibration FI: Tärinäarvot ES: Vibración PT: Vibração EL: Δόνηση TR: Titreşimi SL: Vibracije. HR: Vibracije. SK: Vibrácie. CS: Vibrace PL: Drgania HU: Vibráció RO: Vibrații BG: Вибрации. RU: Вибрация ET: vibratsioon LV: vibrācija LT: Vibracijos JA: 振動。 ZH: 振动 KO: 진동 TH: แรงสั่นสะเทือน MS: Getaran.
17		N	EN: Recoil forces, lance. DE: Rückstoßkraft, Sprühhrohr FR: Forces de recul, lance NL: Terugslagkracht, lans IT: Forze di rinculo, lancia NO: Rekylkraft, lanse SV: Rekylkraft, spolrör DA: Rekylkraft, dyserør FI: Rekyylivoimat, suutin ES: Fuerzas de retroceso, lanza PT: Forças de retrocesso, lança EL: Δυνάμεις οπισθοδρόμησης, διάταξη ψεκασμού χη. TR: Sarmal kuvvetler, boru SL: Povratne sile, šoba. HR: Trzajne sile, mlaznica. SK: Spätný odraz, štandardná striekacia rúra. CS: Síly zpětného rázu, násadec PL: Siły odrzutu, lanca HU: Visszaható erő, szórócső RO: Forțe de recul, tija BG: Сили на откат, крайник. RU: Сила отдачи (распылитель). ET: Tagasilöögi jõud, otsik LV: Atsitiena spēks, smidzinātājs LT: Atatrankos jėga, antgalis JA: 反跳力、ランス。 ZH: 反冲力 (喷杆) KO: 반동력, 랜스 TH: แรงสะท้อนถอยหลัง, ปลายทอ MS: Kuasa sentakan, lans.
18		升	EN: Oil quantity. DE: Ölmenge. FR: Quantité d'huile. NL: Hoeveelheid olie. IT: Quantità olio. NO: Oljemengde. SV: Oljemängd. DA: Oliemængde. FI: Öljymäärä. ES: Cantidad de aceite. PT: Quantidade de óleo. EL: Ποσότητα λαδιού. TR: Yağ miktarı. SL: Količina olja. HR: Količina ulja. SK: Množstvo oleja. CS: Množství oleje. PL: Objętość oleju. HU: Olajmennyiség. RO: Cantitate de ulei. BG: Количество на маслото. RU: Количество масла. ET: Õli kogus. LV: Eļļas daudzums. LT: Tepalo kiekis. JA: オイル量。 ZH: 油量升 KO: 오일량. TH: ปริมาณน้ำมัน MS: Kuantiti minyak.
19			EN: Oil type. DE: Öltyp. FR: Type d'huile. NL: Olietype. IT: Tipo olio. NO: Oljetype. SV: Typ av olja. DA: Olietype. FI: Öljyn tyyppi. ES: Tipo de aceite. PT: Tipo de óleo. EL: Τύπος λαδιού. TR: Yağ tipi. SL: Vrsta olja. HR: Vrsta ulja. SK: Typ oleja. CS: Typ oleje. PL: Typ oleju. HU: Olaj típusa. RO: Tip de ulei. BG: Тип на маслото. RU: Тип масла. ET: Õli tüüp. LV: Eļļas tips. LT: Tepalo tipas. JA: オイルの種類。 ZH: 油型 KO: 오일 유형. TH: ประเภทน้ำมัน MS: Jenis minyak.

20

EN: Specifications and details are subject to change without prior notice. **DE:** Technische Daten und Details des Geräts können sich ohne vorherige Ankündigung ändern. **FR:** Ces spécifications et détails sont susceptibles d'être modifiés sans préavis. **NL:** Specificaties en details kunnen zonder voorafgaande waarschuwing worden gewijzigd. **IT:** Specifiche e dettagli sono soggetti a modifiche senza preavviso. **NO:** Spesifikasjonene og detaljene er gjenstand for endringer uten forutgående varsel. **SV:** Specifikationer och information kan ändras utan föregående meddelande. **DA:** Ret til ændringer i konstruktion og specifikationer forbeholdes. **FI:** Rakenteeseen ja teknisiin tietoihin voidaan tehdä muutoksia ilmoittamatta niistä ennalta. **ES:** Las especificaciones y los datos están sujetos a cambios sin previo aviso. **PT:** As especificações e os detalhes estão sujeitos a alterações sem aviso prévio. **EL:** Τα τεχνικά χαρακτηριστικά και οι λεπτομέρειες υπόκεινται σε αλλαγές χωρίς προηγούμενη ειδοποίηση. **TR:** Özellikler ve ayrıntılar, önceden haber verilmeden değiştirilebilir. **SL:** Tehnični podatki in podrobnosti se lahko spremenijo brez predhodnega obvestila. **HR:** Specifikacije i detalji mogu se mijenjati bez prethodne najave. **SK:** Špecifikácie a podrobnosti sa môžu meniť bez predchádzajúceho upozornenia. **CS:** Technické údaje a detaily mohou být změněny i bez předchozího upozornění. **PL:** Specyfikacje i parametry mogą zostać zmienione bez uprzedzenia. **HU:** A műszaki adatok és részletek előzetes értesítés nélkül megváltozhatnak. **RO:** Specificațiile și detaliile pot fi modificate fără înștiințare prealabilă. **BG:** Спецификациите и детайлите подлежат на промяна без предварително уведомление. **RU:** Технические характеристики и данные могут изменяться без предварительного извещения. **ET:** Tehnilisi kirjeldusi ja üksikasju võidakse muuta eelneva etteteatamiseta. **LV:** Specifikācijas un detaļas var tikt mainītas bez iepriekšēja paziņojuma. **LT:** Konstrukcija ir specifikacijos gali keistis be išankstinio įspėjimo. **JA:** 仕様および情報は事前通知無しに変更する場合があります。 **ZH:** 规格和详情如有变更，恕不另行通知。 **KO:** 사양 및 내용은 예고없이 변경될 수 있습니다. **TH:** ข้อกำหนดเฉพาะและรายละเอียดสามารถเปลี่ยนแปลงได้โดยไม่ต้องแจ้งให้ทราบล่วงหน้า **MS:** Spesifikasi dan butiran adalah tertakluk kepada perubahan tanpa notis terlebih dahulu.



HEAD QUARTER

DENMARK

Nilfisk A/S
Kornmarksvej 1
DK-2605 Broendby
Tel.: (+45) 4323 8100
www.nilfisk.com

SALES COMPANIES

ARGENTINA

Nilfisk Argentina
Herrera 1855 Piso 4° B Ofic 405
Ciudad de Buenos Aires
Tel.: (+54) 11 6091 1576
www.nilfisk.com.ar

AUSTRALIA

Nilfisk Pty Ltd
Unit 1/13 Bessemer Street
Blacktown NSW 2148
Tel.: (+61) 2 98348100
www.nilfisk.com.au

AUSTRIA

Nilfisk GmbH
Metzgerstrasse 68
5101 Bergheim bei Salzburg
Tel.: (+43) 662 456 400 90
www.nilfisk.at

BELGIUM

Nilfisk n.v.-s.a.
Riverside Business Park
Boulevard Internationalelaan 55
Bâtiment C3/C4 Gebouw
Bruxelles 1070
Tel.: (+32) 24 67 60 50
www.nilfisk.be

BRAZIL

Nilfisk do Brasil
Av. Eng. Luis Carlos Berrini, 550
40 Andar, Sala 03
SP - 04571-000 Sao Paulo
Tel.: (+11) 3959-0300 / 3945-4744
www.nilfisk.com.br

CANADA

Nilfisk Canada Company
240 Superior Boulevard
Mississauga, Ontario L5T 2L2
Tel.: (+1) 800-668-8400
www.nilfisk.ca

CHILE

Nilfisk S.A. (Comercial KCS Ltda)
Salar de Llamara 822
8320000 Santiago
Tel.: (+56) 2684 5000
www.nilfisk.cl

CHINA

Nilfisk
4189 Yindu Road
Xinzhuang Industrial Park
201108 Shanghai
Tel.: (+86) 21 3323 2000
www.nilfisk.cn

CZECH REPUBLIC

Nilfisk s.r.o.
VGP Park Horní Počernice
Do Čertous 1/2658
193 00 Praha 9
Tel.: (+420) 244 090 912
www.nilfisk.cz

DENMARK

Nilfisk Danmark A/S
Industrivej 1
Hadsund, DK-9560
Tel.: 72 18 21 20
www.nilfisk.dk

FINLAND

Nilfisk Oy Ab
Koskelontie 23 E
02920 Espoo
Tel.: (+358) 207 890 600
www.nilfisk.fi

FRANCE

Nilfisk SAS
26 Avenue de la Baltique
Villebon sur Yvette
91978 Courtabouef Cedex
Tel.: (+33) 169 59 87 00
www.nilfisk.fr

GERMANY

Nilfisk GmbH
Guido-Oberdorfer-Straße 2-10
89287 Bellenberg
Tel.: (+49) (0)7306/72-444
www.nilfisk.de

GREECE

Nilfisk A.E.
Αναπαύσεως 29
Κορωπί T.K. 194 00
Tel.: (30) 210 9119 600
www.nilfisk.gr

HOLLAND

Nilfisk B.V.
Versterkerstraat 5
1322 AN Almere
Tel.: (+31) 036 5460760
www.nilfisk.nl

HONG KONG

Nilfisk Ltd.
2001 HK Worsted Mills
Industrial Building
31-39, Wo Tong Tsui St.
Kwai Chung, N.T.
Tel.: (+852) 2427 5951
www.nilfisk.com

HUNGARY

Nilfisk Kft.
II. Rákóczi Ferenc út 10
2310 Szigetszentmiklós-Lakihegy
Tel.: (+36) 24 475 550
www.nilfisk.hu

INDIA

Nilfisk India Limited
Pramukh Plaza, 'B' Wing, 4th floor,
Unit No. 403
Cardinal Gracious Road, Chakala
Andheri (East) Mumbai 400 099
Tel.: (+91) 22 6118 8188
www.nilfisk.in

IRELAND

Nilfisk
1 Stokes Place
St. Stephen's Green
Dublin 2
Tel.: (+35) 3 12 94 38 38
www.nilfisk.ie

ITALY

Nilfisk SpA
Strada Comunale della Braglia, 18
26862 Guardamiglio (LO)
Tel.: (+39) (0) 377 414021
www.nilfisk.it

JAPAN

Nilfisk Inc.
1-6-6 Kita-shinyokohama, Kouhoku-ku
Yokohama, 223-0059
Tel.: (+81) 45548 2571
www.nilfisk.com

MALAYSIA

Nilfisk Sdn Bhd
Sd 33, Jalan KIP 10
Taman Perindustrian KIP
Sri Damansara
52200 Kuala Lumpur
Tel.: (60) 3603 627 43 120
www.nilfisk.com

MEXICO

Nilfisk de Mexico, S. de R.L. de C.V.
Pirineos #515 Int.
60-70 Microparque
Industrial WSantiago
76120 Queretaro
Tel.: (+52) (442) 427 77 00
www.nilfisk.com

NEW ZEALAND

Nilfisk Limited
Suite F, Building E
42 Tawa Drive
0632 Albany Auckland
Tel.: (+64) 9 414 1996
Website: www.nilfisk.com

NORWAY

Nilfisk AS
Bjørnerudveien 24
1266 Oslo
Tel.: (+47) 22 75 17 80
www.nilfisk.no

PERU

Nilfisk S.A.C.
Calle Boulevard 162, Of. 703, Lima
33- Perú
Lima
Tel.: (511) 435-6840
www.nilfisk.com

POLAND

Nilfisk Sp. Z.O.O.
Millenium Logistic Park
ul. 3 Maja 8, Bud. B4
05-800 Pruszków
Tel.: (+48) 22 738 3750
www.nilfisk.pl

PORTUGAL

Nilfisk Lda.
Sintra Business Park
Zona Industrial Da Abrunheira
Edifício 1, 1° A
P2710-089 Sintra
Tel.: (+351) 21 911 2670
www.nilfisk.pt

RUSSIA

Nilfisk LLC
Vyatskaya str. 27, bld. 7/1st
127015 Moscow
Tel.: (+7) 495 783 9602
www.nilfisk.ru

SINGAPORE

Den-Sin
22 Tuas Avenue 2
639453 Singapore
Tel.: (+65) 6268 1006
www.densin.com

SLOVAKIA

Nilfisk s.r.o.
Bancikovej 1/A
SK-821 03 Bratislava
Tel.: (+421) 910 222 928
www.nilfisk.sk

SOUTH AFRICA

Nilfisk (Pty) Ltd
Kimbult Office Park
9 Zeiss Road
Laser Park
Honeydew
Johannesburg
Tel.: +27118014600
www.nilfisk.co.za

SOUTH KOREA

Nilfisk Korea
#204 2F Seoulsup Kolon Digital
Tower
25 Seongsuil-ro 4-gil, Seongdong-gu
Seoul.
Tel.: (+ 82) 2 3474 4141
www.nilfisk.co.kr

SPAIN

Nilfisk S.A.
Torre d'Ara,
Passeig del Rengle, 5 Plta. 10ª
08302 Mataró
Tel.: (34) 93 741 2400
www.nilfisk.es

SWEDEN

Nilfisk AB
Taljegårdsgatan 4
431 53 Mölndal
Tel.: (+46) 31 706 73 00
www.nilfisk.se

SWITZERLAND

Nilfisk AG
Ringstrasse 19
Kircheberg/Industri Stelz
9500 Wil
Tel.: (+41) 71 92 38 444
www.nilfisk.ch

TAIWAN

Nilfisk Ltd
Taiwan Branch (H.K.)
No. 5, Wan Fang Road
Taipei
Tel.: (+88) 6227 00 22 68
www.nilfisk.tw

THAILAND

Nilfisk Co. Ltd.
89 Soi Chokechai-Ruammitr
Viphavadee-Rangsit Road
Ladyao, Jatuchak, Bangkok 10900
Tel.: (+66) 2275 5630
www.nilfisk.co.th

TURKEY

Nilfisk A.S.
Serifali Mh. Bayraktar Bulv. Sehiz
Sk. No:7
Ümraniye, 34775 Istanbul
Tel.: +90 216 466 94 94
www.nilfisk.com.tr

UNITED ARAB EMIRATES

Nilfisk Middle East Branch
SAIF-Zone
P.O. Box 122298
Sharjah
Tel.: (+971) (0) 655-78813
www.nilfisk.com

UNITED KINGDOM

Nilfisk Ltd.
Nilfisk House, Bowerbank Way
Gilwilly Industrial Estate, Penrith
Cumbria CA11 9BQ
Tel.: (+44) (0) 1768 868995
www.nilfisk.co.uk

UNITED STATES

Nilfisk, Inc.
9435 Winnetka Ave N,
Brooklyn Park
MN- 55445
www.nilfisk.com

VIETNAM

Nilfisk Vietnam
No. 51 Doc Ngu Str.
P. Vinh Phúc, Q.Ba Dinh
Hanoi
Tel.: (+84) 761 5642
www.nilfisk.com

